

**BMW REMOTE KEYLESS-ENTRY  
SECURITY SYSTEM  
OWNER'S MANUAL**



## TABLE OF CONTENTS

---

<b>INTRODUCTION</b> .....	1
<b>FEATURES</b> .....	2
<b>SYSTEM COMPONENTS AND FUNCTIONS</b>	
1. System Diagram .....	5
2. Remote Control Transmitter .....	5
3. Control Unit .....	6
4. Soft 'Chirp' Siren .....	6
5. Status LED .....	6
<b>SYSTEM OPERATION</b>	
1. Remote Control Locking/Arming .....	7
2. Remote Control/Key Unlocking/Disarming .....	7
3. Panic Mode .....	8
4. Remote Control Selectable 'Chirp' .....	8
<b>REMOTE CONTROL TRANSMITTER BATTERY REPLACEMENT</b>	
1. Battery Replacement .....	9
2. Precautions .....	10
<b>CODE-LEARNING INITIALIZATION PROCEDURE</b> .....	11
<b>SPECIFICATIONS</b> .....	13
<b>QUICK CHECK INSTRUCTIONS</b>	

## INTRODUCTION

---

### Dear BMW Owner:

Congratulations on your purchase of the optimum protection for your BMW and for you! The BMW Remote Keyless-Entry Security System employs highly sophisticated technology to provide convenience and peace of mind, coupled with maximum protection, and reliability for your BMW.

The system incorporates two major components; a control unit and a remote control transmitter. A microprocessor controlled, solid state unit concealed within the vehicle is the 'brain' of the system. The pocket size remote control transmitter allows you to turn the security system 'on' or 'off' from outside the vehicle as well as locking or unlocking the doors and trunk. The transmitter can also be used to activate the alarm intentionally in case of emergency.

To take full advantage of your security system, we encourage you to take the time to read this manual thoroughly.

### ***BMW of North America, Inc.***

**Note:** *Due to the expertise and time required to properly install the BMW Remote Keyless-Entry Security System, we highly recommend that the installation be done by your authorized BMW dealer. Proper wiring, component placement, and adjustment are essential for optimum system performance.*

This device complies with FCC Rule Part 15. Operation is subject to the following two conditions:  
(1) This device may not cause harmful interference, and, (2) This device must accept any interference that may be received, including interference that may cause undesired operation.

## FEATURES

---

- **Factory prewired connectors**  
Direct, plug-in connection to factory prewired harness insures reliable operation and ease of installation.
- **Rolling code anti-scanning system**  
The security system access code automatically changes every time the remote control transmitter button is operated to prevent the code from being intercepted and copied by radio frequency duplicating equipment.
- **Code Learning**  
The system can learn up to four different remote transmitter codes to provide convenience and flexibility to add or replace remotes.
- **Microprocessor design, low current draw**  
Low current consumption components and circuitry are employed to conserve battery power when the security system is in operation.
- **Alarm mode disconnection protection memory**  
If a thief attempts to defeat the system in an alarmed state, (after it has been tripped), by disconnecting the power, the control module memory returns to the alarmed state as soon as power is restored.
- **Two, 2-button remote control transmitters**  
Two ergonomically designed radio frequency remotes provide keyless entry convenience.
- **Remote control locking/unlocking of doors and trunk**  
Convenient one button double-locking or unlocking for fast access to your car.
- **Remote control arming/disarming of the alarm**
- **Disarm by ignition key**  
If the remote control transmitter is lost, misplaced, or the lithium battery goes dead, the system can be disarmed by the ignition key, (refer to #2 of the 'System Operation' section on page 7).
- **Remote control activated panic mode**  
In case of emergency, the remote control transmitter can be used to activate/deactivate the panic mode, sound the siren and flash the hazard lights for a sixty second duration.
- **Remote control selectable (On/Off) acoustical confirmation 'chirp'**  
This feature permits you to switch the siren 'chirp' sound on for audible confirmation during remote arming/disarming, or off if you find the 'chirp' sound to be undesirable.

- **Soft 'chirp' siren**

The soft 'chirp' siren installed in the engine compartment provides discrete confirmation 'chirps' during arming or disarming with the remote, or sounds at full volume when the security system has been triggered.

- **Open door warning**

If a door, the hood, or trunk are not completely closed when you arm/lock the vehicle with the remote control, the siren will emit three warning 'chirps'. The system cannot be armed until all doors, hood and trunk are completely closed.

- **Ignition, fuel injection, and starter motor interruption\***

With the security system armed, the theft deterrent system is engaged preventing operation of ignition/fuel injection systems, and the starter motor.

- **Monitor all doors**

With the system armed, if any door is opened the alarm triggers within five seconds.

- **Monitor engine compartment hood\***

If the hood is opened while the system is armed, the alarm is triggered immediately.

- **Monitor trunk**

The alarm is triggered immediately if the trunk is opened with the system armed.

- **Glass breakage monitoring microphone**

Employs a precision microphone that selectively audits the frequency at which glass is broken or struck by a metal object.

- **Automatic rearming at the end of 60-second alarm cycle**

- **Status LED with 36-hour battery-save automatic turn off function**

After 36 hours of continuous (armed) alarm operation, the LED will discontinue flashing in order to conserve battery power, however, the system is still armed.

- **Tripped warning and sensor identification**

When disarming by remote control transmitter the system will indicate whether your system has been triggered, and which sensor(s) were tripped in your absence.

**Tripped Warning**

The security system alerts you that it had been tripped by flashing a repetitive two blink pattern prior

to disarming, and sounding four 'chirps' upon remote disarming.

### **Tripped Sensor Indication**

The status LED will blink a repetitive pattern to indicate which sensor(s) had triggered the alarm as follows:

<u>Sensor</u>	<u>Number of flashes</u>
Door	1
Trunk/Hood	2
Glass Breakage (or attempt to break glass)	3

Example 1: Alarm triggered by the glass breakage detector.

The LED will blink a repetitive three flash pattern for one minute, or until the ignition switch is turned 'ON'.

Example 2: Alarm triggered by the glass breakage detector and an open door.

The LED will blink a repetitive three flash pattern followed by one flash alternately for one minute, or until the ignition switch is turned 'ON'.

*The Tripped Sensor feature will not function when the system is disarmed using the ignition key.*

*The tripped sensor memory is cleared as the ignition is turned 'ON' or when the system is rearmed.*

- **Sensor cancellation**

After the alarm has been triggered for ten sixty-second alarm cycles by the same sensor(s), the alarm will automatically rearm itself and selectively ignore the offending sensor(s).

- **Flashing hazard lights\*\***

The hazard lights will flash for the duration of the alarm panic cycle (sixty seconds), when the alarm is triggered.

- **Dome light surveillance\*\***

As the system is disarmed using the remote control transmitter, the dome lights will illuminate to permit a visible check of the interior before entry.

\* *Beginning with 1994 M.Y. vehicles, excluding early production 325 convertible models.*

\*\* *Flashing hazard lights and dome light surveillance features apply to 1993 M.Y. and newer vehicles. Dome light surveillance not available on 1996 M.Y. Z3 vehicles.*

## SYSTEM COMPONENTS AND FUNCTIONS

### 1. System Diagram

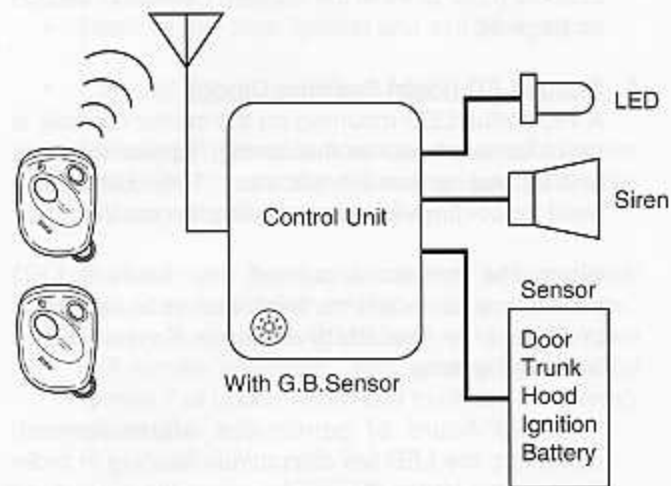

### 2. Remote Control Transmitter

#### Button-1

- Press and release this button to:  
*Lock and arm the system.*
- Press and hold for more than two seconds to:  
*Activate panic mode.*



#### Button-2

- Press and release this button to:  
*Unlock and disarm the system.*

#### Both Buttons Simultaneously

- Press and hold for more than two seconds to:  
*Switch the acoustical 'chirp' confirmation 'ON/OFF'.*

#### LED Indicator

The LED illuminates when a control signal is being transmitted.

*Low battery indication: When the intensity (brightness) of the LED is decreased (dimmed), replace the battery. Refer to the battery replacement procedure on page 9.*

### 3. **Control Unit**

A microprocessor controlled, solid state unit concealed within the vehicle monitors the doors, glass, hood, and trunk. The control unit receives and interprets command signals from the remote control transmitter.

A glass breakage monitoring microphone built into the control unit triggers the alarm in response to the sound of breaking glass, or a metal object striking the glass.

#### **Glass Breakage Sensitivity Adjustment**

The control unit incorporates internal switches which are set during installation by your authorized BMW dealer to specify the sensitivity threshold for the glass breakage microphone.

*Readjustment of these switches should only be performed by your authorized BMW dealer to avoid alarm malfunction and false alarms.*

### 4. **Soft 'Chirp' Siren**

A soft 'chirp' siren installed in the engine compartment will sound at full volume when the system is triggered. A soft 'chirp' acoustical confirmation is provided while arming/disarming with the remote control transmitter, or as an open door

warning. If desired, the 'chirp' can selectively be switched 'on/off' using the remote control transmitter buttons, (refer to #4 of the 'System Operation' section on page 8).

### 5. **Status LED (Light Emitting Diode)**

A red status LED mounted on the center console is used for alarm status monitoring, tripped warning, and tripped sensor identification. The LED is also used for confirmation when coding the control unit.

When the system is armed, the flashing LED indicates to a 'would be thief' that your vehicle is protected by the BMW Remote Keyless-Entry Security System.

*After 36 hours of continuous alarm (armed) operation, the LED will discontinue flashing in order to conserve battery power, however, the system will still be armed.*



## SYSTEM OPERATION

### 1. Remote Control Locking/Arming

- Close windows, sunroof, and convertible top.
- Remove key from ignition and exit the vehicle.
- Close all doors, trunk, and hood.
- Press and release Button-1 on the remote control transmitter to lock the doors and trunk. The siren will emit one confirmation 'chirp'.

*If a door, the hood, or trunk are not completely closed the siren will emit three warning 'chirps', (Open Door Warning feature), and the system will remain unarmed. The system can only be armed if all doors, hood, and trunk are completely closed.*



### 2. Remote Control/Key Unlocking/Disarming

It is possible to unlock/disarm the system by remote control or by using the ignition key.

#### Remote Control Unlocking/Disarming

- Press and release Button-2 on the remote control transmitter. All the doors and trunk will be unlocked and the system will be disarmed. The siren will emit two confirmation 'chirps'.

#### Ignition Key Unlocking/Disarming

- Insert key into the driver door key slot and unlock the door. The doors and trunk will be unlocked, however, the system will remain armed.
- Open the door, and switch the ignition key to 'ON' position. The system will be disarmed.

*The alarm will trigger within five seconds after any door is opened unless the system is disarmed by switching the ignition key to the 'ON' position.*

*This disarm method should be employed if you have lost or misplaced your remote control transmitter.*

*The Tripped Sensor feature will not function when key disarming is employed.*

### 3. Panic Mode

In either armed or disarmed condition, the alarm can be activated intentionally in case of an emergency by using the remote control transmitter.

#### **To Activate Panic Function**

- Press and hold Button-1 on the remote control transmitter for more than two seconds. The siren will sound for one alarm duration (60 seconds), and the hazard lights will flash. To reactivate the panic function, press and hold Button-1 again.

#### **To Cancel Panic Function**

- Press and hold either Button-1 or Button-2 on the remote control transmitter for more than two seconds, or turn the ignition key to 'ON' position. The siren and hazard flash will be cancelled.

### 4. Remote Control Selectable 'Chirp'

The 'chirp' sound emitted by the siren during arming/disarming can be turned 'ON/OFF'.

- Press and hold Button-1 and Button-2 simultaneously for more than two seconds to switch back and forth between 'chirp' 'ON/OFF'.

*The siren will emit four confirmation 'chirps' to indicate when the 'chirp' is 'ON'.*

*The status LED will blink twice to indicate when the 'chirp' is 'OFF'.*



## REMOTE CONTROL TRANSMITTER BATTERY REPLACEMENT

### 1. Battery Replacement (See Illustration)

Normal battery life is one year, however, it may vary depending on the conditions and amount of usage. To replace:

1. Place the transmitter on a soft flat surface with the buttons facing downward. Remove the two bottom cover screws using a small Phillips screwdriver.

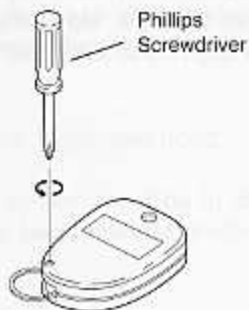

2. Gently remove the bottom cover taking care not to misplace the key ring.



3. Remove and properly dispose of the old battery, and insert a new battery (#CR2032). Make sure the battery polarity is correct.

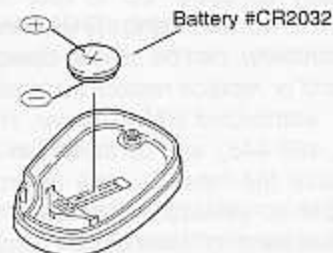

4. Replace the bottom cover insuring that the key ring is properly positioned.

5. Reinstall and tighten the two bottom cover screws.
6. Press any button to confirm that the LED indicator light is bright. If not, repeat the above procedure and check the battery polarity.

**2. Precautions**

- *Never submerge your remote control transmitter in water.*
- *Avoid exposing your remote control transmitter to extreme heat or cold conditions.*
- *Each remote transmitter contains its own unique security ID code. Up to four different remote control transmitters, (including the original transmitters), can be used to operate your system. To add or replace remote transmitters, order from your authorized BMW dealer, (Part number 82 11 1 469 448), and be certain to have the dealer initialize the new ID code in order for the new remote to operate your system, (refer to the 'Code-Learning Initialization Procedure' section on page 11).*

*If you have lost your remote control transmitter, be sure to delete the remote ID code by following the procedures described in the 'Code-Learning*

*Initialization Procedure' on page 11, or have your authorized BMW dealer perform this procedure to avoid theft of your vehicle.*

- *Use your remote control transmitter only when necessary. Battery power is being consumed each time you press a transmitter button.*
- *The ring on the remote control transmitter is designed for attachment to your primary key ring. To avoid damage, **do not** use this ring as the primary key ring to hold your keys.*



## CODE-LEARNING INITIALIZATION PROCEDURE

---

Each remote transmitter has a unique identification (ID) code. In order for a replacement remote to operate your security system, or to delete the ID code from a lost remote, you must follow the procedures detailed below so that your system's control module will learn/delete the desired ID code(s). This code-learning initialization procedure must be followed precisely within the sequence and time constraints specified, in order for the procedure to be carried out successfully. Consult your authorized BMW dealer for assistance, or to perform the initialization procedure if you prefer.

### Preparation

1. Close all doors, trunk, and hood.
2. The security system must be in 'disarm' mode. The key must be removed from the ignition key slot.

### Enter Code-Learning Mode

3. Open the trunk and leave it opened.
4. Open the driver's door and sit in the driver's seat.
5. Close the driver's door.

6. Cycle the ignition switch five times between the 'OFF' position and position 2, (ignition 'ON', all dash warning lamps will illuminate). The red status LED will illuminate continuously, and the siren will 'chirp' once, to indicate that the code-learning mode has been initiated.

*Do not start the engine.*

*The ignition switch cycling in step #6 must be performed within ten seconds.*

*The sequence in steps #1-#6 must be performed within 45 seconds.*

### Register/Delete ID Code(s)

7. Open driver's door, (remain seated in driver's seat).
8. Close driver's door.
9. Press and release any button on the remote you wish to register into the system. The status LED will shut off momentarily to indicate that one ID code has been registered.
10. Repeat steps 7 through 9 to register the remaining three ID codes.

*It is possible for the system to memorize a total of four different ID codes. As a new code is initialized into memory, the oldest code in memory is automatically deleted. If you had lost your remotes and wished to delete the lost remote ID codes from memory, you could initialize the ID code from a newly purchased replacement transmitter four times thereby deleting the previous ID codes from system memory.*

#### **Exiting Code-Learning Mode:**

11. Open driver's door, and exit from vehicle, leaving the door opened.
12. Close trunk.
13. Close driver's door. The LED will turn off and the siren will 'chirp' twice.
14. The initialization procedure is now completed; test all remotes to confirm operation.

## **SPECIFICATIONS**

---

### **Control Unit**

Design.....	Microprocessor, all solid state
Operating Voltage .....	12 V DC (10 V - 16 V allowable)
Siren Sound Pressure Level .....	120dB/m at 12 V DC
Output Type/Maximum Current	
Siren (positive) .....	2 A
Door lock/Unlock (positive/negative) .....	0.1 A
System Current Draw	
Unarmed .....	3 mA
Armed .....	4 mA
Triggered .....	0.75 A
Operating Temperature .....	-30 °C to +70 °C (-22 °F to +158 °F)
Dimensions .....	107mm x 153mm x 25mm (4-1/4" x 6" x 1")
Net Weight .....	0.2 Kg ( 7 oz)

### **Remote Control Transmitter**

Transmitter Type .....	Radio frequency
Range .....	Average 50 Feet
Battery Type .....	Lithium (#CR2032)
Battery Life .....	1 Year (Typical)
Operating Temperature .....	-20 °C to +60 °C (-4 °F to +140 °F)
Dimensions.....	42mm x 52mm x 13.5mm (1-5/8" x 2-1/16" x 1/2")
Net Weight .....	.20 g (0.7 oz)

**NOTE: For product improvement, specifications and design are subject to change without notice.**

## QUICK CHECK INSTRUCTIONS

- **To lock doors/trunk and arm system:**  
*Push and release Button-1 (one 'chirp')*
- **To unlock doors/trunk and disarm system:**  
*Push and release Button-2 (two 'chirps')*
- **Panic mode activate:**  
*Push and hold Button-1 for more than 2 seconds.*  
(Siren will sound, and hazard lights will flash)
- **Panic mode cancel:**  
*Push and hold Button-1 or 2 for more than 2 seconds.* (Siren and hazard light flash will stop)
- **Disarm system or cancel panic mode without remote transmitter:**  
*Insert ignition key and turn to 'ON' position*
- **Tripped sensor indication (after disarming system):**
  - Door sensor 1 flash
  - Trunk/Hood 2 flashes
  - Glass breakage 3 flashes  
(or attempt to break glass)



82 11 1 469 444P (Port Kit)  
82 11 1 469 444 (Option Kit)  
01 21 1 469 450 (Manual)